

(19) World Intellectual Property Organization
International Bureau



(43) International Publication Date
21 December 2000 (21.12.2000)

PCT

(10) International Publication Number
WO 00/76430 A1

(51) International Patent Classification⁷: A61F 5/48

(21) International Application Number: PCT/NL00/00370

(22) International Filing Date: 30 May 2000 (30.05.2000)

(25) Filing Language: Dutch

(26) Publication Language: English

(30) Priority Data:
1012368 16 June 1999 (16.06.1999) NL

(71) Applicant (for all designated States except US): GOYARTS B.V. [NL/NL]; Gemulleboekenweg 59b, NL-5062 CA Oisterwijk (NL).

(72) Inventor; and

(75) Inventor/Applicant (for US only): GOYARTS, Gregorius, Maria, Hubertus [NL/NL]; Henog Hendriklaan 6, NL-5062 CJ Oisterwijk (NL).

(74) Agent: BARENDREGT, F.; Exter Polak & Charlois B.V., P.O. Box 3241, NL-2280 GE Rijswijk (NL).

(81) Designated States (national): AE, AG, AL, AM, AT, AU, AZ, BA, BB, BG, BR, BY, CA, CH, CN, CR, CU, CZ, DE, DK, DM, DZ, EE, ES, FI, GB, GD, GE, GH, GM, HR, HU, ID, IL, IN, IS, JP, KE, KG, KP, KR, KZ, LC, LK, LR, LS, LT, LU, LV, MA, MD, MG, MK, MN, MW, MX, MZ, NO, NZ, PL, PT, RO, RU, SD, SE, SG, SI, SK, SL, TJ, TM, TR, TT, TZ, UA, UG, US, UZ, VN, YU, ZA, ZW.

(84) Designated States (regional): ARIPO patent (GH, GM, KE, LS, MW, MZ, SD, SL, SZ, TZ, UG, ZW), Eurasian patent (AM, AZ, BY, KG, KZ, MD, RU, TJ, TM), European patent (AT, BE, CH, CY, DE, DK, ES, FI, FR, GB, GR, IE, IT, LU, MC, NL, PT, SE), OAPI patent (BF, BJ, CF, CG, CI, CM, GA, GN, GW, ML, MR, NE, SN, TD, TG).

Published:

- - With international search report.
- Before the expiration of the time limit for amending the claims and to be republished in the event of receipt of amendments.

For two-letter codes and other abbreviations, refer to the "Guidance Notes on Codes and Abbreviations" appearing at the beginning of each regular issue of the PCT Gazette.

(54) Title: WASHABLE ABSORBENT PAD AND A METHOD FOR MANUFACTURING SAME.

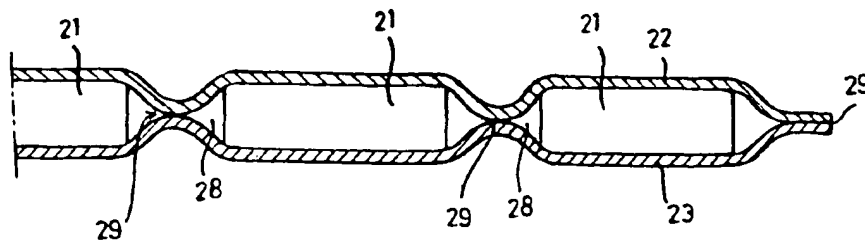

WO 00/76430 A1

(57) Abstract: The invention relates to a washable pad comprising a moisture-absorption element (21) which is positioned between a moisture-permeable top-layer material (22) and a moisture-impermeable bottom-layer material (23), wherein the said top-layer material (22), bottom-layer material (23) and the moisture-absorption element (21) are at least locally joined to one another to form a cohesive unit, wherein the moisture-impermeable bottom-layer material (23), on the side which faces towards the moisture-absorption element (21), is coated over at least part of its surface with a layer of bonding material which bonds together the moisture-absorption element (21) and the bottom-layer material (23). In particular, the invention describes a pad in which a moisture-permeable top-layer material (22) and a moisture-impermeable bottom-layer material are joined together at certain points via perforations (28) in the moisture-absorption body (21). The invention also relates to a method for forming the abovementioned washable pad and to ways of finishing the border of a washable pad of this nature.

Short title: WASHABLE ABSORBENT PAD AND A METHOD FOR MANUFACTURING SAME

The invention relates firstly to a washable pad, at least comprising an assembly of a moisture-absorption element which is positioned between a moisture-permeable top-layer material and a moisture-impermeable bottom-layer material, each with a thickness and an area which are such that the materials have substantially the same surface area and, in the position of use, the top surface of the moisture-absorption element bears against the bottom surface of the moisture-permeable top-layer material and the bottom surface of the absorption element bears against the top surface of the moisture-impermeable bottom-layer material, and in which the moisture-permeable top-layer material, the moisture-absorption element and the moisture-impermeable bottom-layer material are joined together to form a single unit,

Washable pads of this nature are used as protection on, for example, a mattress, in order to prevent them from becoming soiled, for example when used by incontinent patients.

The pad collects any soiling instead of the mattress; once it has been washed, the pad can be reused.

In the preceding text, the terms top and bottom surface relate to the orientation of these surfaces in the position of use of a pad, i.e. on top of a mattress or other base, with the moisture-permeable top-layer material facing upwards.

A washable pad of this nature is known from US-A-3,965,503. This publication describes a washable pad of the type described in which the join between the above layers is brought about by stitching.

The moisture-impermeable character of the bottom-layer material is brought about by providing the bottom-layer material with a moisture-impermeable coating subsequent to the stitching operation, for example by applying a molten coating of polyvinyl chloride, followed by cooling of this coating so that it solidifies.

One drawback of this known washable pad is that, owing to the presence of a sealing coating layer on the outside of the bottom-layer material, it becomes stiff since this coating

- 2 -

layer, in order to be moisture-impermeable, has to be relatively heavy.

Sealing is necessary because moisture can pass downwards from the patient along the stitches, so that a good seal is
5 necessary.

The object of the present invention is to provide an improved washable pad of the above type and is characterized in that between two out of the moisture-permeable top-layer material, the moisture-absorption element and the moisture-
10 impermeable bottom-layer material, there is a form of bonding, over at least part of the surface thereof, which differs from the form of bonding between the third out of the moisture-permeable top-layer material, the moisture-absorption element and the moisture-impermeable bottom-layer and one of the above
15 two, or there is no bonding at all, while the moisture-impermeable bottom-layer material is intrinsically moisture-impermeable. Intrinsically moisture-impermeable is intended to mean that the material in question is impermeable to moisture without requiring any further treatment.

Starting from an intrinsically moisture-impermeable
20 bottom-layer material makes the pad easier to manufacture, considerably improves the flexibility of the washable pad and, as a result of the layers being attached to one another in different ways, the flexibility of the pad can be optimized on
25 the one hand and, on the other hand, optimum fixing of the layers with respect to one another is achieved.

In connection with the invention described above, reference is also made to US-A-5,099,532, which describes a principle for joining together the various layers which exhibits
30 some resemblance to the method used in the present invention.

In the above publication, a moisture-permeable top layer is joined to an absorption body by means of stitching; then, strips of material are placed against the moisture-absorption body on the underside and are then joined to the assembly of top
35 layer and absorption body by additional stitching. On their side which is remote from the absorption body, the strips have a thermoplastic coating. Then, a moisture-impermeable bottom-layer material is placed against the underside of the absorption body; on the side facing towards the absorption body, the bottom-layer

- 3 -

material has a layer of thermoplastic. By exerting pressure and/or supplying heat, the thermoplastic layer of the strips is joined to the thermoplastic layer of the bottom-layer material, so that the three layers are joined together.

5 The use of a number of ways of joining moisture-permeable top-layer material to moisture-absorption element and of special strips for securing purposes make this pad complicated to manufacture, while the presence of strips which are coated with thermoplastic and joined to the bottom layer has
10 an adverse effect on the flexibility of the pad.

In an attractive embodiment of the washable pad according to the invention, bonding is present between the moisture-permeable top-layer material and the moisture-impermeable bottom-layer material via perforations, which are
15 present in the moisture-absorption element, in the form of bonding points.

The presence of a bond between the moisture-permeable top-layer material and the moisture-impermeable bottom-layer material firstly produces excellent fixing of the various layers
20 with respect to one another; there is no need for any further bonding of the third layer, which in this case is therefore the moisture-absorption element. The dimensions of the perforations are selected in such a manner that the moisture-permeable top-layer material of the moisture-impermeable bottom-layer material
25 can easily make contact with one another in order to be bonded together under the influence of heat and/or pressure. Bonding can be brought about using, for example, HF, ultrasonic or thermal spot welding; obviously, bonding can also be achieved with the aid of a locally-applied bonding-agent. The dimensions
30 of the perforations are not critical, provided that the abovementioned condition concerning contact is satisfied. Good results are obtained with perforations with a diameter of between 10 and 50 mm; in one specific case, perforations with a diameter of 25 mm gave good results. The centre-to-centre
35 distance may be from 50-400 mm, preferably 100-200 mm.

In the case outlined here, there is bonding between the moisture-permeable top-layer material and the moisture-impermeable bottom-layer material, while there is no bonding

- 4 -

between the moisture-absorption element and one of the other layers.

The use of a moisture-absorption element with perforations is known per se from NL-B-1009034, in the name of the applicant. The perforations allow rapid drying of the absorption element following washing of the pad. The perforations for promoting drying are generally of smaller dimensions than those discussed above for forming the bond between the moisture-permeable top-layer material and the moisture-impermeable bottom-layer material. The perforations which promote drying may, for example, have a diameter of 1-5 mm with a centre-to-centre distance of 8-30 mm. A practical embodiment has perforations with a diameter of approximately 3 mm and a centre-to-centre distance of approximately 12 mm. In the embodiment outlined above, in which there are relatively large perforations for bonding the moisture-permeable top-layer material to the moisture-impermeable bottom-layer material, there may therefore be two types of perforations: small perforations in a relatively large density for drying purposes and large perforations in a relatively small density for bonding purposes. Obviously, it is also possible only to have perforations for bonding purposes. To provide a border finish, the absorption element may be of smaller size than the moisture-permeable top-layer material and the moisture-impermeable bottom-layer material, and the said top-layer material and bottom-layer material are then bonded together.

If appropriate, to promote the bonding, thermoplastic may be arranged on the top and/or bottom surface of the moisture-permeable top-layer material, or the top surface of the moisture-impermeable bottom-layer material, at the location of the borders and/or the perforations for bonding, in order to promote the bonding between top-layer material and bottom-layer material in those regions.

In the washable pad described above, there is also expediently a border finish in which the moisture-impermeable bottom-layer material is turned over onto the top surface of the moisture-permeable top-layer material and is bonded thereto.

In an alternative embodiment of the washable pad according to the invention, the moisture-impermeable bottom-

- 5 -

layer material, on the side which faces towards the moisture-absorption element, is coated, over at least part of its surface, with a layer of bonding material which bonds the moisture-absorption element and the bottom-layer material together.

The bonding between the moisture-absorption element and moisture-permeable top-layer material may be of numerous types, as will be explained in more detail below; it is possible to select stitching; stepping/quilting; needling, HF/ultrasonic welding, etc.

In the case described above, it is also expedient to have a border finish in which moisture-impermeable bottom-layer material bears against and is bonded to the moisture-permeable top-layer material, for example by turning over the bottom-layer material so that it bears against and bonds to the top-layer material.

The latter embodiment can be used to very good effect if there is no bonding between the moisture-absorption element and the moisture-permeable top-layer material.

Starting from an intrinsically moisture-impermeable bottom-layer material and bonding the said material to the moisture-absorption element with the aid of a layer of bonding material also results in a considerably more flexible washable pad compared with the pad which is known from the prior art as described above.

The bonding material as referred to above may, on the one hand, be a thermoplastic bonding material which displays its action as a result of heat being supplied, with the result that the bonding material melts and materials which are bearing against one another stick together.

Bonding is brought about by cooling to below the melting point of the thermoplastic. The bonding material may also be a material which crosslinks, optionally with heat being supplied, which can no longer be reactivated once it has carried out a bonding action of this type.

The moisture-impermeable bottom-layer material may be combined with any desired moisture-permeable top-layer material and moisture-absorption element, and the join between the

- 6 -

moisture-absorption element and the moisture-permeable top-layer material may also be of any desired type.

As is discussed in more detail below, this join between the moisture-absorption element and the moisture-permeable top-layer material may be brought about by stitching or stepping/quilting which is known in the prior art. Stepping/quilting involves making up two or more layers, for example of moisture-permeable top-layer material and moisture-absorption element, over the entire surface thereof in a preselected pattern. It is also possible for moisture-permeable top-layer material and moisture-absorption element to be bonded together using, for example, a spot coating layer of bonding material which, as stated above, is a thermoplastic material or a material which crosslinks, optionally with heat being supplied.

The invention also relates to a method for forming a washable pad in which a moisture-permeable top-layer material is placed against the top surface of a moisture-absorption element, and a moisture-impermeable bottom-layer material is placed against the bottom surface thereof, and the moisture-permeable top-layer material, the moisture-absorption element and the moisture-impermeable bottom-layer material are joined together to form a single unit, which is characterized in that, between two out of the moisture-permeable top-layer material, the moisture-absorption element and the moisture-impermeable bottom-layer material, over at least part of the mutually facing surfaces thereof, bonding is brought about by supplying heat and/or exerting pressure, while bonding of a different type is brought about between the third out of the moisture-permeable top material, the moisture-absorption element and the moisture-impermeable bottom-layer material and one of the said two, or there is no bonding whatsoever, while the starting material for the moisture-impermeable bottom-layer material is intrinsically moisture-impermeable.

As described above with regard to the product, it is possible, by suitably selecting the bonding methods, to provide the washable incontinence pad with a high level of flexibility; optimum fixing of the layers with respect to one another is

- 7 -

ensured, and, as will be explained in more detail, the method is suitable for a high degree of automation.

In an advantageous embodiment, the washable pad according to the invention also includes bottom-layer material, or a similar material, in the border regions, and this material bears against and bonds to the top-layer material.

The moisture-absorption element used may be any known moisture-absorption element which generally comprises a combination of moisture-absorbent fibres and, if appropriate, a moisture-dispersing layer on one or both sides.

Very good results are obtained with a moisture-absorption element such as that which is described in WO-97/34554 in the name of the applicant, in which a moisture-absorption element comprises a mixture of chemical and synthetic fibres which are brought together in a layer, with liquid-dispersing layers of synthetic fibres present on the top and bottom sides of the layer.

A moisture-absorption element of this nature typically comprises <100%, for example 90-10%, chemical fibres and up to 100, for example 10-90%, synthetic fibres, while one or more liquid-dispersing layers which substantially comprise synthetic fibres are bonded to the top and bottom sides (percentages are by weight). In a specific case, the liquid-absorbent layer contains 90-60% chemical fibres, such as viscose or modified viscose, and 10-40% synthetic fibres, such as polyester, polyamide, polyacrylate, polypropylene, and the like.

In the present context, the term chemical fibre is understood to mean a fibre which is based on a natural product, such as cellulose, and has been made into a form which is suitable for human use by means of a chemical treatment. A synthetic fibre is a fibre which is produced from a polymer which is prepared entirely by chemical synthesis and in which there is no natural product base.

Another advantageous embodiment of the absorption element described above and produced by the applicant is described in Dutch Patent 1009034, in the name of the applicant, as referred to above, in which the absorption element, in order to improve its drying properties, is provided with a large

- 8 -

number of perforations which extend over at least part of the height of the absorption element.

The top-layer material may also be of numerous types, provided that it exhibits good permeability to moisture and is substantially hydrophobic.

Expediently, the top-layer material is, for example, a knitted fabric comprising fibres, such as polyester, polyamide, polyethylene, etc. It should be noted that good results have also been obtained with mixed materials, such as with synthetic/natural fibres, one example of which is 50%/50% polyester/cotton. It is even possible to use 100% cotton, if the absorption capacity of the absorption element is sufficiently high.

Suitable results are obtained, for example, with a polyester knitted fabric which, on the side which comes into contact with the patient, has been roughened so that a soft surface is obtained.

In an attractive embodiment, the method which is described in general terms above is characterized in that a moisture-absorption element is provided with perforations distributed over its surface, which perforations extend through the entire thickness of this element, and in at least some of the perforations the moisture-permeable top-layer material and the moisture-impermeable bottom-layer material are brought into contact with one another and bonded to one another by supplying heat and/or exerting pressure, so that bonding points are formed.

The embodiment described above is eminently suitable for automation in a production line.

The moisture-permeable top-layer material, the absorption-body material which is provided with perforations and the moisture-impermeable bottom-layer material are for this purpose fed to a processing unit in the form of webs; by exerting pressure, for example air pressure, contact is brought about between the moisture-permeable top-layer material and the moisture-impermeable bottom-layer material in the region of the perforations; bonding between the said layers is brought about in the region of a selected number of perforations with the aid of the abovementioned techniques, such as welding or adhesive

- 9 -

bonding; the assembled web which is formed in this way is divided into pieces in the size of a washable pad by cutting and, in line or off line, a border finish is produced, if necessary, as will be described in more detail below.

5 The border finish may firstly be brought about by making the moisture-absorption element smaller than the moisture-permeable top-layer material and the moisture-impermeable bottom-layer material and by bonding the top-layer material and bottom-layer material together at the borders. To improve the
10 bonding, it is possible, at the location of the borders and/or the perforations for bonding, to provide the top-layer material (which is permeable), on the top and/or bottom surface, or the top surface of the moisture-impermeable bottom-layer material, with thermoplastic which contributes to the ease and speed of
15 bonding.

With regard to the border finish, in the embodiment described above this may expediently be carried out in such a manner that the surface area of the moisture-impermeable bottom-layer material is made larger than the surface area of the
20 moisture-absorption element and the moisture-permeable top-layer material, and in the border regions the moisture-impermeable bottom-layer material is turned over onto the moisture-permeable top-layer material and is joined thereto.

In a fully automated method, if this embodiment is used,
25 it will be possible for the border finish to be realized in the transverse direction of the web by carrying this finish out after the web has been divided into pieces with a longitudinal border finish, for which purpose a strip of moisture-permeable top-layer material/moisture-absorption material is cut away at
30 the location of the transverse edge. It is also possible to feed pieces of assembled moisture-permeable top-layer material/moisture-absorption element of suitable dimensions to a web of moisture-impermeable bottom-layer material, and the entire border finish can be carried out after the materials
35 which have been assembled to form the pad sandwich structure have been divided into pieces.

In another embodiment of the method according to the invention, an assembly is formed from a moisture-absorption element and a moisture-permeable top-layer material which bears

- 10 -

against its top surface, and then a moisture-impermeable bottom-layer material is placed against the bottom surface of the moisture-absorption element, a layer of bonding material being provided over at least part of the surface of the moisture-impermeable bottom-layer material, on its side facing towards the moisture-absorption element, after which this moisture-impermeable bottom-layer material is joined to the moisture-absorption element, which forms part of the assembly, by supplying heat and/or exerting pressure.

The assembly of a moisture-absorption element and a top-layer material, to which the moisture-impermeable bottom-layer material is joined, may, in an expedient embodiment, be formed in a step which precedes the method described above.

The moisture-absorption element and the top-layer material can be joined in various ways, for example by:

a) stitching;

b) stepping/quilting;

c) needling;

d) joining by means of high-frequency or ultrasonic welding;

e) joining using a spot coating layer of bonding material which is present on that side of the top-layer material which faces towards the moisture-absorption element, by supplying heat and/or exerting pressure; and

f) joining using a spot coating layer of bonding material on that side of the moisture-absorption element which faces towards the top-layer material by supplying heat and/or exerting pressure.

If options e or f are used for the assembly, a coating method which differs from the spot coating method will expediently be selected for bonding together the moisture-impermeable bottom-layer material and the moisture-absorption element by means of a bonding agent.

In the embodiment described under e and f above, it is possible, in a first option, for a thermoplastic material to be present in the interface between top-layer material and moisture-absorption element. The thermoplastic material may form part of the said layers; it may also be applied separately.

However, the top-layer material and moisture-absorption element may also be joined together as a result of the presence

- 11 -

of a crosslinkable material. With a view to the speed of production, crosslinking will generally be brought about under the influence of heat. If a very high speed is not required, it is possible to use materials which crosslink under ambient
5 conditions. In the latter case, pressure will generally be applied in order to hold the materials in good contact with one another during crosslinking of the bonding material.

Examples of thermoplastic bonding materials which may be mentioned are polyvinyl chloride, polyethylene, polypropylene,
10 polyurethane and the like.

Examples of bonding materials which crosslink, optionally with heat being supplied, which may be mentioned are isocyanates and cyanoacrylates which crosslink under the influence of atmospheric humidity (for example crosslinkable
15 PU); epoxy resin/hardener combinations; polyester resin/hardener combinations, etc.

In another attractive embodiment of the method according to the invention, the assembly of a moisture-absorption element and a top-layer material is formed at the same time as the
20 moisture-impermeable bottom-layer material and the moisture-absorption element are joined together.

The formation of the assembly as referred to above may be carried out in numerous ways, as indicated; in one attractive embodiment, this formation takes place either by using a spot
25 coating layer of bonding material which is present on that side of the top-layer material which faces towards the moisture-absorption element or by using a spot coating layer of bonding material on that side of the moisture-absorption element which faces towards the top-layer material. The (spot) coating of
30 bonding material may be thermoplastic or, as stated above, crosslinkable, optionally under the influence of heat.

If the bonding material between the top-layer material and the moisture-absorption element and between the moisture-absorption element and the bottom-layer material is
35 thermoplastic, when a heat treatment, if appropriate with the application of pressure, which is used to join the bottom-layer material to the moisture-absorption element in the latter embodiment, is carried out, the thermoplastic bonding material which is present in the interface region between the top-layer

- 12 -

material and the moisture-absorption element will also be activated, with the result that the top-layer material and the moisture-absorption element will be stuck together.

If the bonding material in the boundary layer between
5 the top-layer material and the moisture-absorption element and
in the boundary layer between the moisture-absorption element
and the bottom-layer material crosslinks under the action of
heat, once again the formation of the assembly is brought about
and the bottom-layer material is bonded to this assembly in a
10 single heat treatment.

If the bonding material in both boundary layers is crosslinkable under ambient conditions, it is generally sufficient to apply pressure for a sufficient time.

The bonding material which is present in the boundary
15 region between the top-layer material and the moisture-
absorption element is generally, if used, present in the form of
a spot coating layer, in order to present the minimum possible
obstacle to the passage of moisture from the patient side of the
pad to the moisture-absorption element.

20 The thermoplastic bonding material which is present as a
component of the bottom-layer material may either be present in
a spot coating layer or as a completely covering layer.

The bottom-layer material may be a moisture-impermeable
material such as polyvinyl chloride, polyethylene or
25 polyurethane which is itself thermoplastic or may be a rubber-
like non-thermoplastic material which, on the bonding side, is
coated with a bonding layer of thermoplastic material.

On the outer side which is directed away from the
moisture-absorption element, the moisture-impermeable bottom-
30 layer material may, if appropriate, be in the form of a layer
which reduces the sliding properties and/or a decorative layer.

The decorative layer may be obtained by printing or by lamination of, for example, a textile layer.

To join the moisture-impermeable bottom-layer material
35 and the moisture-absorption element it is possible, for example,
to select heating and/or the exertion of pressure over the
entire surface of the bottom-layer material; however, it is also
possible to select heating and/or exertion of pressure in a
pattern.

- 13 -

In the latter method according to the invention, it is also important to ensure a good border finish of the washable pad.

In certain cases, there is no need for a special border finish to take place, and at the border the stacked arrangement of at least the moisture-impermeable bottom-layer material, the moisture-absorption element and the moisture-permeable top-layer material, as well as any other layers, is visible. This embodiment will be sufficient in particular if the bonding layer of thermoplastic or crosslinkable material is applied over the entire surface of the bottom-layer material.

If the bottom-layer material is provided with a layer of bonding material over part of its surface, for example in the form of a spot coating layer, it is recommended to provide finishing material which is expediently formed by bottom-layer material or a similar material. In a first embodiment of the method according to the invention, the surface area of the bottom-layer material is larger than the surface area of the assembly of the top-layer material and the moisture-absorption element and projects partially beyond this assembly; by folding over the projecting parts and bringing them into contact with the top-layer material, it is possible, by suitable heating and/or exertion of pressure, to join the bottom-layer material to the outside of the top-layer material.

In this context, heating is also understood to include welding, such as HF or ultrasonic welding.

In this method, the bonding layer of thermoplastic or crosslinkable material is activated in such a way that bonding has occurred after sticking followed by cooling.

In another embodiment, separate strips of bottom-layer material are brought into contact with the top side of the top-layer material and the bottom side of the bottom-layer material by being folded over, and this bottom-layer material is then joined to the top-layer material and the bottom-layer material.

In yet another embodiment, the bottom-layer material is selected to be of larger surface area than the absorption element and a top-layer material which bears against the latter; the bottom-layer material is folded upwards along the borders of the pad and is fixed around the top surface of the top-layer

- 14 -

material using a separate strip of bottom-layer material. The strip of bottom-layer material on one side is bonded to the bottom-layer material which has the bonding layer facing upwards and on the other side it is joined to the top-layer material.

5 The invention will now be described with reference to the drawing, in which:

Fig. 1 shows a diagrammatic cross-sectional view through a pad according to the invention;

10 Fig. 2 shows a border finish of the pad from Fig. 1, in a first embodiment;

Fig. 3 shows a border finish in a second embodiment; and

Fig. 4 shows a border finish in a third embodiment;

15 Fig. 5 diagrammatically depicts an embodiment in which the moisture-permeable top-layer material and the moisture-impermeable bottom-layer material are joined to one another via perforations which are present in the moisture-absorption element;

Fig. 6 shows an embodiment as in Fig. 5, with an alternative border finish.

20 Fig. 1 shows a diagrammatic cross section through a pad, in which the moisture-absorption element is denoted by 1, the moisture-permeable top-layer material is denoted by 2 and the moisture-impermeable bottom-layer material is denoted by 3. The boundary surface between the moisture-absorption element 1 and
25 the moisture-permeable top-layer material 2 is formed by 4; in the case illustrated, bonding has been effected with the aid of a layer of thermoplastic bonding material which is arranged in the said boundary surface 4 in the form of a spot coating layer. The spot coating layer is expediently applied to that side of
30 the top-layer material 2 which faces towards the moisture-absorption element 1.

The boundary surface between the moisture-absorption element 1 and the moisture-impermeable bottom layer 3 is formed by the boundary surface 5.

35 In this arrangement, although not shown, a layer of thermoplastic bonding material is also used to join the moisture-absorption element 1 and the moisture-impermeable bottom layer 3.

- 15 -

The layer of thermoplastic bonding material is applied to the bottom layer 3 over the entire surface. The thermoplastic may also be arranged in the form of a pattern.

The above text has made numerous references to a layer
5 of thermoplastic bonding material which is present as a separate layer on the moisture-impermeable bottom layer 3.

Obviously, it is also possible for the entire layer 3 to be made from a thermoplastic material which is the same as the material of the bonding layer. In the latter case, it is
10 possible, by suitably selecting the thickness of the layer 3, to ensure the desired flexibility of the washable pad.

The assembly of moisture-absorption element 1 and moisture-permeable top-layer material 2 may obviously also be produced, as described above, by stitching or stepping/quilting.
15 In the cases discussed here, however, the moisture-impermeable bottom-layer material 3 is joined to the moisture-absorption element 1 with the aid of a layer of thermoplastic bonding material, in which case the layer of bonding material and the moisture-impermeable bottom-layer material 3 may, if
20 appropriate, have the same function.

The bonding material used in this embodiment shown in Figure 1 was crosslinkable polyurethane which was applied by spraying. Another application techniques involves screen-
printing.

25 Bonding took place by applying a pressure of 2-10 kg/cm² and by heating at 135°C.

If an isocyanate coating which cures under the influence of atmospheric humidity is used, curing took place under ambient conditions (15-25°C), likewise with the application of pressure
30 (2-10 kg/cm²).

An excellent flexible pad material was obtained both when using a thermoplastic material and when using a curable bonding material.

In addition to the above-described bottom-layer material
35 3, moisture-absorption element 1 and top-layer material 2, it is possible for a plurality of further layers of material to be present, depending on the precise function of the washable pad.

Additional layers of material may, for example, be formed by a spacer layer, such as a knitted fabric of synthetic

- 16 -

fibres, between the top-layer material 2 and the absorption element 1, in order to prevent the patient/user from suffering bed sores (decubitus) and to shorten the drying time, still further.

5 It is also possible for a PU foam layer of the type described in Hygienic Products with superabsorbent polyurethane foam; Jeff Patterson, Nonwovens World, April/May 1999 to be included, for example between the bottom-layer material 3 and the absorption element 1.

10 The PU foam layer consists of hydrophilic PU.

The function of a layer of this nature is to absorb moisture, prevent decubitus and to accelerate drying after washing. Fig. 2 shows the same cross section as that shown in Fig. 1, but in this case, to finish the pad, the moisture-
15 impermeable bottom layer 3 has been folded over so that it bears against the top side of the top-layer material 2, after which the bottom-layer material 3 can be bonded to the top-layer material 2 by means of a heat treatment, so as to form boundary layers 6 and 7. In this way, an excellent liquid-tight border
20 finish is obtained.

Fig. 3 shows an alternative form of finish for a washable pad according to the invention, in which a strip 8 of bottom-layer material which is provided with a bonding layer of thermoplastic material is placed against the moisture-permeable
25 top layer 2 and the moisture-impermeable bottom layer 3 by being folded over. Bonding between the strip 8 and the top-layer material 2 and the bottom-layer material 3 is brought about by heat treatment. The strip of material 8 may consist of the same material as the bottom-layer material 3; obviously, it is also
30 possible to select another material with a similar action. This border finish is likewise extremely liquid-tight.

Fig. 4 shows yet another variant of a liquid-tight border finish in which the bottom-layer material 3 of the washable pad projects beyond the surface of the moisture-
35 absorption element, is folded upwards and is then fixed to a separate strip 12 of bottom-layer material 3 or similar material on the top side of the top-layer material 2.

It should be noted that it is not strictly necessary to fold the bottom-layer material upwards; in view of the

- 17 -

relatively small thickness of the pad, the projecting part of the bottom-layer material 3 and the separate strip 12 can also be bonded together without any folding.

5 The pad according to the invention is extremely flexible and pleasant for the patient to use; it can be washed without boiling at 95°C, while sterilization can be carried out in an autoclave at 135°C. The bonding material used was in this case a thermoplastic polyurethane material.

10 As the bonding layer of thermoplastic material it is possible to select from numerous thermoplastic materials, such as polyvinyl chloride, polyethylene, polyamide, polyurethane, etc.; numerous other materials will be immediately obvious to the person skilled in the art.

15 In connection with the embodiments described above as shown in Figs. 2, 3 and 4, it is pointed out that, due to the border finish shown in those figures, which is always produced by fixing bottom-layer material around the borders, it is possible to obtain an absolutely liquid-tight border finish which substantially prevents moisture from flowing towards the
20 region outside the pad.

In US-A-3,965,503, referred to above, by way of example a border finish using a bias strip or an overcast seam is described, the attachment being brought about by means of stitching. Obviously, leakage can still occur at these stitches.
25 This is prevented altogether with the border finish according to the invention.

The invention makes it possible to provide a washable pad which, starting from the separate components or partial assemblies thereof, makes it possible to produce the pad in a
30 fully automated and continuous method.

The various components or assemblies thereof can be supplied in web form and then, by suitable processing and/or heat treatment, formed into separate, completely finished, washable pads according to the invention.

35 Figure 5 diagrammatically depicts a washable pad having a moisture-absorption body 21, a top layer 22 of moisture-permeable material and a bottom layer 23 of moisture-impermeable material.

- 18 -

Perforations in the moisture-absorption body 21 are denoted by 28.

In the perforations 28, contact is brought about between the moisture-permeable top-layer material 22 and the moisture-impermeable bottom-layer material 23, and bonding has taken place so as to form bonding points 29.

The number of bonding points is not critical, provided that good fixing of the layers 21, 22 and 23 with respect to one another is obtained. In a test, good results were obtained with a tetragonal arrangement of perforations with a side of 10 cm.

Distances between the points of between 5 and 25 cm are generally suitable. The size of the perforations is equally uncritical provided that they do allow the moisture-permeable top-layer material 22 and moisture-impermeable bottom-layer material to be joined to one another.

In addition to the perforations 28 which have suitable dimensions for bonding, it is also possible, as discussed above, for smaller perforations to be present, the purpose of which is primarily to assist with drying.

As can be seen in the figure, the moisture-impermeable bottom-layer material 23 is turned over at the borders and is bonded to the top side of the moisture-permeable top-layer material 22 using a bonding surface 26.

As stated above, the bonding points 29 may be formed in numerous ways; thermal, high-frequency or ultrasonic spot welding are attractive options in those cases in which both the moisture-permeable top-layer material 22 and the moisture-impermeable bottom-layer material 23 consist at least to a significant extent of thermoplastic fibres or materials.

It is also possible for the border finish to be brought about under the same condition using one of the said welding techniques; with surface contact being used instead of a spot action. If the moisture-absorption element also consists to a large extent of thermoplastic material, it is also possible for the border of the entire pad to be compressed over its thickness so as to fuse together, with the result that a very good moistureproof border is obtained.

Figure 6 shows a situation in which the moisture-absorption element 21 is smaller than the moisture-permeable

- 19 -

top-layer material 22 and moisture-impermeable bottom-layer material 23 and bonds 29 are also formed in the border regions. The bonds may be made between the two materials directly; bonding can be promoted by the presence of thermoplastic (PE, 5 FF, PU) on the top and/or bottom surface of the moisture-permeable top-layer material 22 at the location of the borders and/or the perforations 28. Due to the moisture-permeable nature of the top-layer material 22, good bonding promotion will also be found when thermoplastic is applied to the top surface of the 10 top-layer material; in the situation represented diagrammatically in Figure 6, thermoplastic was applied to the top surface.

It is preferable for thermoplastic to be applied only to the borders; in addition to promoting adhesion, the application 15 of thermoplastic also causes the top layer to become impermeable to liquid, with the result that excellent closure is obtained at the borders.

The above text has always referred to a washable pad for use as such. In an adapted size and/or shape, the washable pad 20 can also function as a sanitary towel, incontinence products, a bib for babies or adults, a medical bandage, an operation pad, etc. This technique can also be employed for the manufacture of washable diapers and washable incontinence pants for adults, and washable cleaning cloths.

- 20 -

CLAIMS

1. Washable pad, at least comprising an assembly of a moisture-absorption element (1, 21) which is positioned between
5 a moisture-permeable top-layer material (2, 22) and a moisture-impermeable bottom-layer material (3, 23), each with a thickness and an area which are such that the materials (1, 2, 3; 21, 22, 23) have substantially the same surface area and, in the position of use, the top surface of the moisture-absorption
10 element (1, 21) bears against the bottom surface of the moisture-permeable top-layer material (2, 22) and the bottom surface of the absorption element (1, 21) bears against the top surface of the moisture-impermeable bottom-layer material (3, 23), and in which the moisture-permeable top-layer material
15 (2, 22), the moisture-absorption element (1, 21) and the moisture-impermeable bottom-layer material (3, 23) are joined together to form a single unit, characterized in that, between two out of the moisture-permeable top-layer material (2, 22), the moisture-absorption element (1, 21) and the moisture-
20 impermeable bottom-layer material (3, 23), there is a form of bonding, over at least part of the surface thereof, which differs from the form of bonding between the third out of the moisture-permeable top-layer material (2, 22), the moisture-absorption element (1, 21) and the moisture-impermeable bottom-
25 layer (3, 23) and one of the above two, or there is no bonding at all, and the moisture-impermeable bottom-layer material (3, 23) is intrinsically moisture-impermeable.

2. Washable pad according to claim 1, characterized in that
30 bonding is present between the moisture-permeable top-layer material (22) and the moisture-impermeable bottom-layer material (23) via perforations (28), which are present in the moisture-absorption element (21), in the form of bonding points (29).

3. Washable pad according to claim 2, characterized in that
35 there is a border finish present, to which end the moisture-absorption element (21) is smaller than the moisture-permeable top-layer material (22) and the moisture-impermeable bottom-layer material (23), and in that the moisture-permeable top-layer material (22) and the moisture-impermeable bottom-layer

- 21 -

material (23) are bonded to one another at the periphery of the washable pad.

4. Washable pad according to claims 2 and 3, characterized in that thermoplastic material is applied to the top and/or
5 bottom surface of the moisture-permeable top-layer material (22), or the top surface of the moisture-impermeable bottom-layer material, at the location of the borders and/or the perforations (28), in order to promote the bonding between the moisture-permeable top-layer material (22) and the moisture-
10 impermeable bottom-layer material (23).

5. Washable pad according to claim 2, characterized in that there is a border finish in which the moisture-impermeable bottom-layer material (23) is turned over onto the top surface of the moisture-permeable top-layer material (23) and is bonded
15 thereto.

6. Washable pad according to claims 1 and 2, characterized in that the moisture-impermeable bottom-layer material (3), on the top surface (5) which faces towards the moisture-absorption element (1), is coated, over at least part of this surface, with
20 a layer of bonding material which bonds the moisture-absorption element (1) and the moisture-impermeable bottom-layer material (3) together.

7. Washable pad according to claim 6, characterized in that, in the border regions thereof, there is also moisture-
25 impermeable bottom-layer material (3, 8, 12) which bears against and bonds to the moisture-permeable top-layer material (2).

8. Method for forming a washable pad in which a moisture-permeable top-layer material (2, 22) is placed at least against the top surface of a moisture-absorption element (1, 21), and a
30 moisture-impermeable bottom-layer material (3, 23) is placed against the bottom surface thereof, and the moisture-permeable top-layer material (2, 22), the moisture-absorption element (1, 21) and the moisture-impermeable bottom-layer material (3, 23) are joined together to form a single unit, characterized
35 in that, between two out of the moisture-permeable top-layer material (2, 22), the moisture-absorption element (1, 21) and the moisture-impermeable bottom-layer material (3, 23), over at least part of the mutually facing surfaces thereof, bonding is brought about by supplying heat and/or exerting pressure, while

- 22 -

bonding of a different type is brought about between the third out of the moisture-permeable top material (2, 22), the moisture-absorption element (1, 21) and the moisture-impermeable bottom-layer material (3, 23) and one of the said two, or there is no bonding whatsoever, while the starting material for the moisture-impermeable bottom-layer material (3, 23) is intrinsically moisture-impermeable.

9. Method according to claim 8, characterized in that a moisture-absorption element (21) is provided with perforations (28) distributed over its surface, which perforations extend through the entire thickness of this element, and in at least some of the perforations (28) the moisture-permeable top-layer material (22) and the moisture-impermeable bottom-layer material (23) are brought into contact with one another and bonded to one another by supplying heat and/or exerting pressure, so that bonding points (29) are formed.

10. Method according to claim 9, characterized in that the moisture-absorption element (21) is made smaller than the moisture-permeable top-layer material (22) and the moisture-impermeable bottom-layer material (23), and in that also the borders of the moisture-permeable top-layer material (22) and moisture-impermeable bottom-layer material (23) are bonded to one another.

11. Method according to claims 9 and 10, characterized in that thermoplastic material is applied to the top and/or bottom surface of the moisture-permeable top-layer material (22), or the top surface of the moisture-impermeable bottom-layer material, at the location of the borders and/or the perforations (28), prior to bonding of the moisture-permeable top-layer material (22) and the moisture-impermeable bottom-layer material (23).

12. Method according to claim 9, characterized in that a border finish is formed, in which the surface area of the moisture-impermeable bottom-layer material (23) is made larger than the surface area of the moisture-absorption element (21) and the moisture-permeable top-layer material (22), and in the border regions the moisture-impermeable bottom-layer material (23) is turned over onto the moisture-permeable top-layer material (22) and is joined thereto.

- 23 -

13. Method according to claim 8, characterized in that an assembly is formed from a moisture-absorption element (1) and a moisture-permeable top-layer material (2) which bears against its top surface, and then a moisture-impermeable bottom-layer material (3) is placed against the bottom surface of the moisture-absorption element (1), a layer of bonding material being provided over at least part of the surface of the moisture-impermeable bottom-layer material (3), on its side (5) facing towards the moisture-adsorption element (1), and in that this moisture-impermeable bottom-layer material (3) is joined to the moisture-absorption element (1), which forms part of the assembly, by supplying heat and/or exerting pressure.

14. Method according to claim 13, characterized in that it comprises a prior step in which the assembly of a moisture-absorption element (1) and a moisture-permeable top-layer material (2) is formed.

15. Method according to claim 14, characterized in that the moisture-absorption element (1) and the moisture-permeable top-layer material (2) are joined to form an assembly with the aid of a method selected from:

- a) stitching;
- b) stepping/quilting;
- c) needling;
- d) joining by means of high-frequency or ultrasonic welding;
- e) joining using a spot coating layer of bonding material which is present on that side of the moisture-permeable top-layer material (2) which faces towards the moisture-absorption element (1), by supplying heat and/or exerting pressure; and
- f) joining using a spot coating layer of bonding material on that side of the moisture-absorption element (1) which faces towards the moisture-permeable top-layer material (2) by supplying heat and/or exerting pressure.

16. Method according to claim 13, characterized in that the assembly of a moisture-absorption element (1) and a moisture-permeable top-layer material (2) is formed at the same time that the bottom-layer material (3) and the moisture-absorption element (1) are joined together.

17. Method according to claim 16, characterized in that the assembly is formed by using a spot coating layer of bonding

- 24 -

material which is present on that side of the moisture-permeable top-layer material (2) which faces towards the moisture-absorption element (1) or by using a spot coating layer of bonding material on that side of the moisture-absorption element (1) which faces towards the moisture-permeable top-layer material (2) and by supplying heat and/or applying pressure.

18. Method according to one or more of claims 14-17, characterized in that in the border regions of the pad which is to be formed, moisture-impermeable bottom-layer material (3) is also placed against the outer surface of the moisture-permeable top-layer material (2) and is joined thereto by supplying heat and/or applying pressure, so as to form a liquid-tight border finish.

19. Method according to claim 18, characterized in that the moisture-impermeable bottom-layer material (3) has a larger surface area than the assembly of the moisture-permeable top-layer material (2) and moisture-absorption element (1) and projects at least partly outside this assembly; and in that the projecting parts are folded over to lay against the moisture-permeable top-layer material (2), to which they are joined.

20. Method according to claim 18, characterized in that separate strips of moisture-impermeable bottom-layer material (3), by being folded over, are made to bear against the top side of the moisture-permeable top-layer material (2) and the bottom side of the moisture-impermeable bottom-layer material (3), and are joined to the moisture-permeable top-layer material (2) and the bottom-layer material (3).

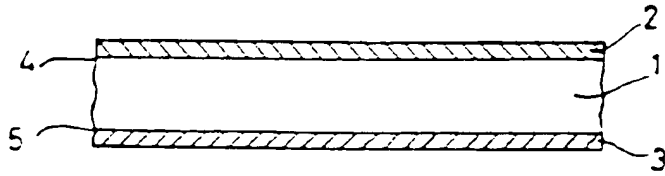

FIG. 1.

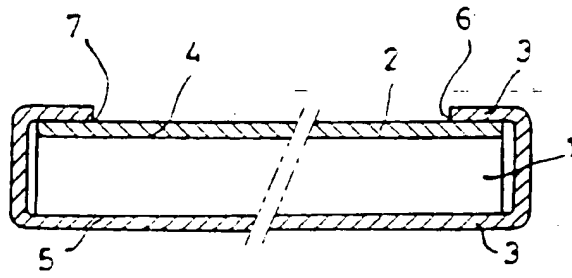

FIG. 2.

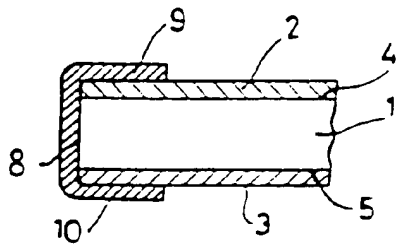
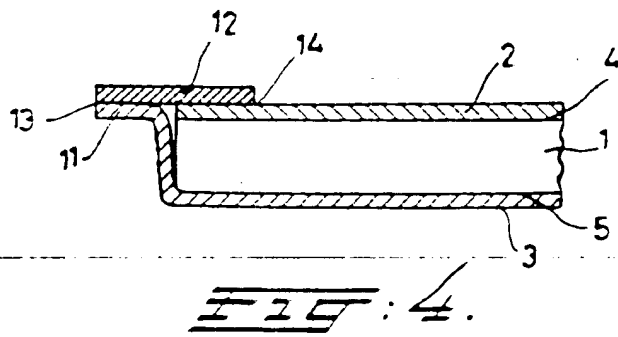

FIG. 3.



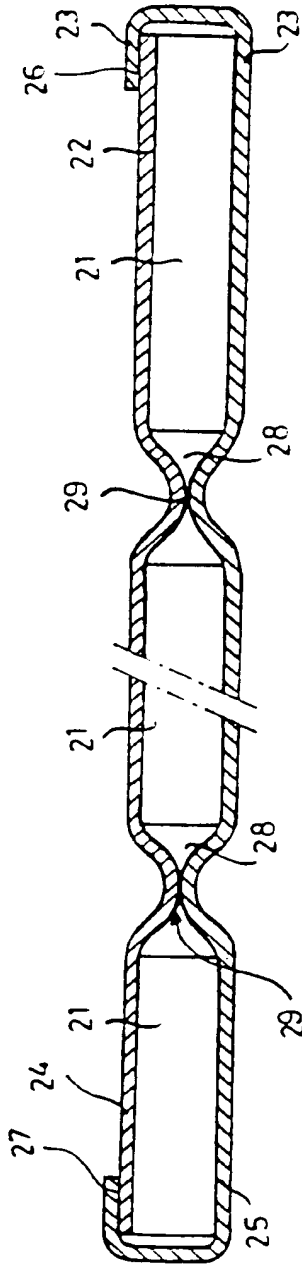

FIG. 5.

SUBSTITUTE SHEET (RULE 26)

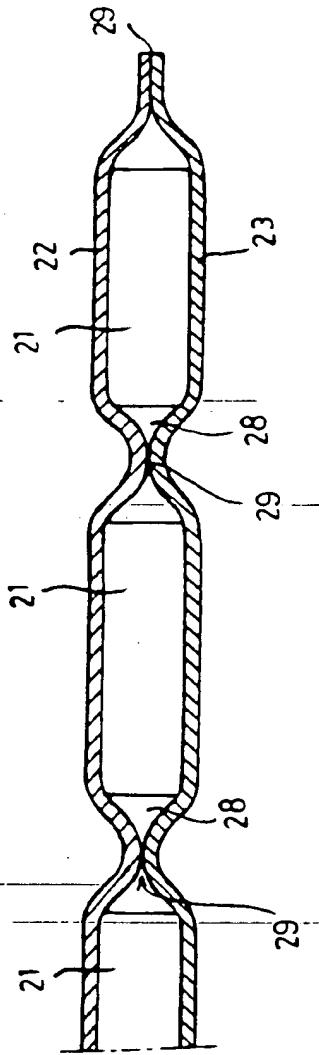

FIG. 6.

SUBSTITUTE SHEET (RULE 26)

INTERNATIONAL SEARCH REPORT

International Application No.

PCT/NL 00/00370

A. CLASSIFICATION OF SUBJECT MATTER
IPC 7 A61F5/48

According to International Patent Classification (IPC) or to both national classification and IPC.

B. FIELDS SEARCHED

Minimum documentation searched (classification system followed by classification symbols)
IPC 7 A61F

Documentation searched other than minimum documentation to the extent that such documents are included in the fields searched

Electronic data base consulted during the international search (name of data base and, where practical, search terms used)

EPO-Internal

C. DOCUMENTS CONSIDERED TO BE RELEVANT

Category *	Citation of document, with indication, where appropriate, of the relevant passages	Relevant to claim No.
X	US 5 099 532 A (THOMAS RICHARD M ET AL) 31 March 1992 (1992-03-31) the whole document ---	1,8, 13-15
X	US 4 844 965 A (FOXMAN CHARLES) 4 July 1989 (1989-07-04) column 4, line 13 - line 34; claims; figures ---	1,8
A		15
A	US 5 249 320 A (BRIER DANIEL L ET AL) 5 October 1993 (1993-10-05) column 5, line 35 -column 7, line 16; claims; figures ---	1
X	EP 0 261 904 A (STANDARD TEXTILE CO INC) 30 March 1988 (1988-03-30) column 7, line 24 -column 8, line 63; claims; figures ---	1,6,8, 13-16 5.12
Y		
	-/--	

Further documents are listed in the continuation of box C.

Patent family members are listed in annex.

* Special categories of cited documents :

- "A" document defining the general state of the art which is not considered to be of particular relevance
- "E" earlier document but published on or after the international filing date
- "L" document which may throw doubts on priority claim(s) or which is cited to establish the publication date of another citation or other special reason (as specified)
- "O" document referring to an oral disclosure, use, exhibition or other means
- "P" document published prior to the international filing date but later than the priority date claimed

- "T" later document published after the international filing date or priority date and not in conflict with the application but cited to understand the principle or theory underlying the invention
- "X" document of particular relevance; the claimed invention cannot be considered novel or cannot be considered to involve an inventive step when the document is taken alone
- "Y" document of particular relevance; the claimed invention cannot be considered to involve an inventive step when the document is combined with one or more other such documents, such combination being obvious to a person skilled in the art.
- "8" document member of the same patent family

Date of the actual completion of the international search:

27 September 2000

Date of mailing of the international search report:

09/10/2000

Name and mailing address of the ISA

European Patent Office, F.E. 5818 Patentaar, 2
NL - 2280 HV Rijswijk
Tel. (+31-70) 340-2040, Tx. 31 651 epo.nl
Fax: (+31-70) 340-3011

Authorized officer:

Douskas, K

INTERNATIONAL SEARCH REPORT

International Application No.

PCT/NL 00/00370

C.(Continuation) DOCUMENTS CONSIDERED TO BE RELEVANT

Category *	Citation of document, with indication, where appropriate, of the relevant passages	Relevant to claim No.
A	US 3 620 894 A (OATES FRANK) 16 November 1971 (1971-11-16) column 4, line 58 - line 65 ---	8,10
X	US 4 216 774 A (GRABER HELEN E) 12 August 1980 (1980-08-12) the whole document ---	1,8
Y	US 2 896 626 A (GRABER) 28 July 1959 (1959-07-28) the whole document ---	5,12
A	US 2 896 626 A (GRABER) 28 July 1959 (1959-07-28) the whole document ---	2,8,9
X	US 3 927 673 A (TAYLOR GLENN N) 23 December 1975 (1975-12-23) the whole document ---	1-3,8-10
Y	US 3 927 673 A (TAYLOR GLENN N) 23 December 1975 (1975-12-23) the whole document ---	4,11
Y	US 5 720 736 A (HATSUDA TAKUMI ET AL) 24 February 1998 (1998-02-24) column 22, line 62 -column 23, line 5 ---	4,11
X	DE 32 05 931 A (SCHICKEDANZ VER PAPIERWERK) 8 September 1983 (1983-09-08) the whole document ---	1,8
A	DE 32 05 931 A (SCHICKEDANZ VER PAPIERWERK) 8 September 1983 (1983-09-08) the whole document ---	15
A	US 3 812 001 A (RYAN A) 21 May 1974 (1974-05-21) the whole document -----	1,2,8,9

Form PCT/ISA,210 (continuation of second sheet) (July 1992)

INTERNATIONAL SEARCH REPORT

Information on patent family members

International Application No.

PCT/NL 00/00370

Patent document cited in search report	Publication date	Patent family member(s)	Publication date
US 5099532 A	31-03-1992	CA 2062706 A, C	19-09-1992
US 4844965 A	04-07-1989	US 4939017 A US 4846822 A	03-07-1990 11-07-1989
US 5249320 A	05-10-1993	US 5269720 A US 5217782 A US 5210882 A US 5291617 A US 5297296 A AU 5380294 A CA 2110765 A EP 0602986 A EP 0602987 A EP 0602988 A JP 6253966 A MX 9400226 A US 5392467 A US 5435014 A AU 5273893 A CA 2109670 A, C JP 6212501 A MX 9400227 A US 5385502 A US 5441436 A CA 2081930 A EP 0542491 A MX 9206493 A US 5306536 A US 5471683 A US 5315717 A AU 3374793 A CA 2089134 A CA 2089535 A EP 0558330 A EP 0558351 A JP 6002201 A MX 9301026 A AU 5188793 A CA 2103406 A JP 7082640 A	14-12-1993 08-06-1993 18-05-1993 08-03-1994 29-03-1994 01-09-1994 18-06-1994 22-06-1994 22-06-1994 22-06-1994 13-09-1994 31-08-1994 28-02-1995 25-07-1995 11-08-1994 18-06-1994 02-08-1994 29-07-1994 31-01-1995 15-08-1995 13-05-1993 19-05-1993 01-10-1993 26-04-1994 05-12-1995 31-05-1994 02-09-1993 27-08-1993 27-08-1993 01-09-1993 01-09-1993 11-01-1994 01-11-1993 30-06-1994 18-06-1994 28-03-1995
EP 0261904 A	30-03-1988	US 4961982 A	09-10-1990
US 3620894 A	16-11-1971	AT 291432 E BE 738499 A CH 509079 A DE 1944579 A FR 2017997 A GE 1271520 A LU 59411 A NL 6913666 A, B SE 345378 B	15-06-1971 16-02-1970 30-06-1971 03-09-1970 29-05-1970 19-04-1972 08-01-1970 11-03-1970 29-05-1972
US 4216774 A	12-08-1980	CA 1111630 A	03-11-1981
US 2896626 A	28-07-1959	NONE	

Form PCT/ISA216 (patent family annex) July 1995

INTERNATIONAL SEARCH REPORT

Information on patent family members

International Application No.

PCT/NL 00/00370

Patent document cited in search report	Publication date	Patent family member(s)	Publication date
US 3927673 A	23-12-1975	AT 352044 B	27-08-1979
		AT 623875 A	15-02-1979
		AU 497380 B	14-12-1978
		AU 8333075 A	27-01-1977
		BE 832344 A	01-12-1975
		BR 7504866 A	03-08-1976
		CA 1029902 A	25-04-1978
		CH 587619 A	13-05-1977
		DE 2535058 A	26-02-1976
		DK 363075 A, E,	13-02-1976
		ES 226062 U	01-08-1977
		ES 227814 U	16-08-1977
		FR 2330339 A	03-06-1977
		GE 1509229 A	04-05-1978
		IE 41647 B	27-02-1980
		IT 1041061 B	10-01-1980
		JP 1324699 C	27-06-1986
		JP 51044055 A	15-04-1976
		JP 60042281 E	21-09-1985
		MX 144519 A	23-10-1981
		NL 7509514 A, E,	16-02-1976
		PH 11726 A	30-05-1978
		SE 400699 E	10-04-1978
SE 7508269 A	13-02-1976		
ZA 7504668 A	23-02-1977		
US 5720736 A	24-02-1998	US 5518761 A	21-05-1996
		DE 69323297 D	11-03-1999
		DE 69323297 T	26-08-1999
		EP 0624618 A	17-11-1994
		WO 9405723 A	17-03-1994
		JP 6256536 A	13-09-1994
		JP 6312000 A	08-11-1994
JP 6328604 A	29-11-1994		
DE 3205931 A	08-09-1983	NONE	
US 3812001 A	21-05-1974	NONE	

THIS PAGE BLANK (USPTO)